

SEIT 1928

KONDENSATORMIKROFONE
FÜR STUDIO - UND MESSTECHNIK**MICROTECH GEFELL**

XY-arrangement

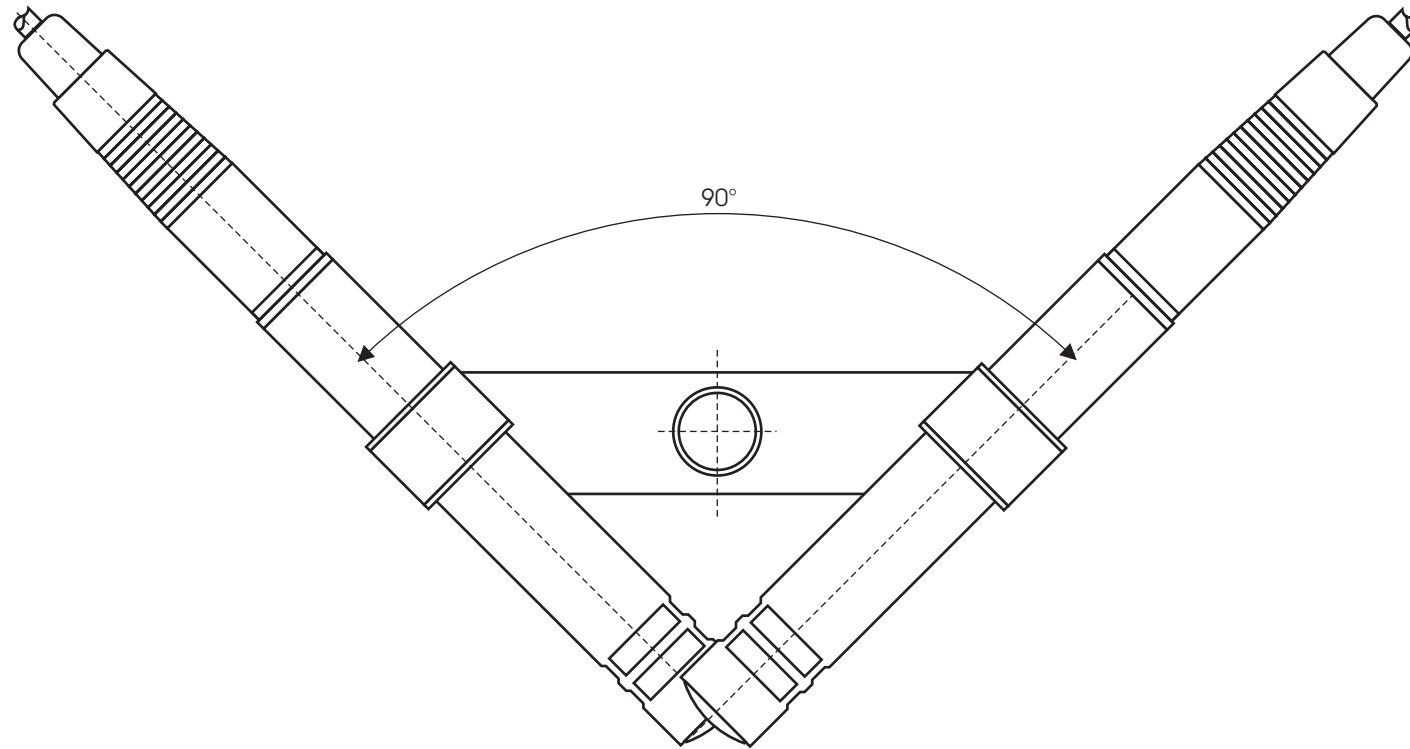
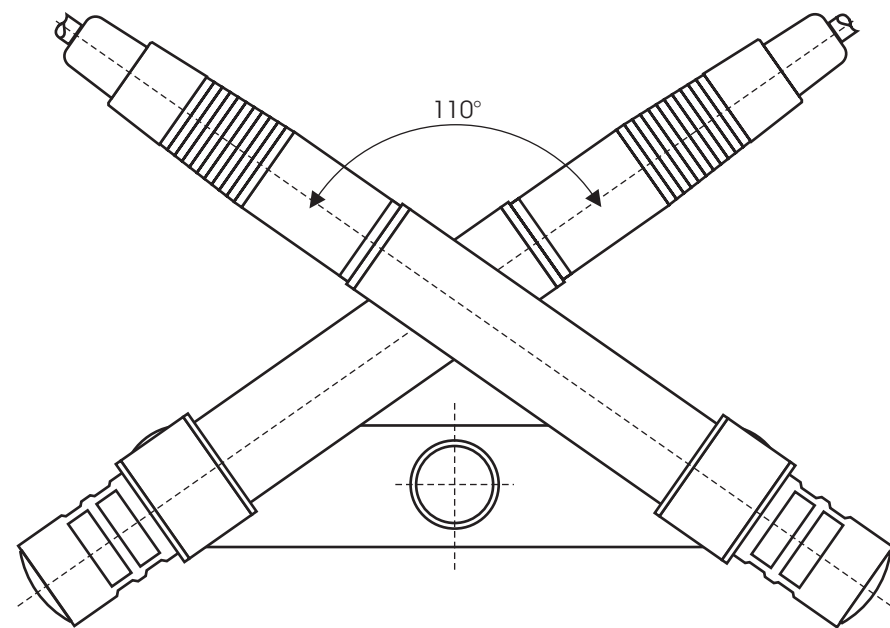

ORTF-arrangement

M 300**Condenser miniature microphone with
Cardioid polar pattern**

The M 300 is a compact condenser microphone in studio quality. The frequency response of the transmission factor is practically linear for a wide range of sound incidence and has a smooth treble boost rising to about 3 dB between 6 and 10 kHz. The miniature microphone is well suited for vocal and instrumental soloists. It permits a lifelike recording also at various sound incidence, e.g. announcer in synchronous studios, speaker, blower.

The M 300 is designed for studio applications in radio, television broadcasting and films for live performance and recording of instruments, vocals and speech and sound reinforcement in the professional and semiprofessional market also under adverse acoustic conditions, e.g. in churches.

A new low-noise integrated hybrid circuit and the transformerless circuit design guarantee an extremely wide dynamic range by a low equivalent loudness level and a high reliability in operation.

RFI susceptibility is very low.

The microphone is powered by a 3-pin XLR connector with the C 70 microphone cable. The power supply is provided by 48 V phantom powering, which is internationally standardized as P 48 in DIN 45596 and IEC 268-15. A two-channel powering is possible with the N 200 power supply.

The finish of the miniature microphone is dark bronze.

**Delivery**

Microphone M 300 in wooden case L x B x H 195 x 68 x 43 mm
dark bronze

Order-No. 211101

Accessories, optional

Windscreen, anthrazit	W 20	Order-No. 202401
Popscreen, black	PO 70	Order-No. 600018
Microphone holder, Ø 21 mm, satin nickel	MH 64	Order-No. 202307
Elastic suspension, dark bronze	EA 20	Order-No. 202342
Elastic suspension, dark bronze	EH 93	Order-No. 202328
Table stand, dunkel bronze	TS 64	Order-No. 212304
Double mount, dunkel bronze	TD 93	Order-No. 212332
Gooseneck, black	ME 90	Order-No. 202324
Power supply	N 200	Order-No. 202101
Connection cable	C 70	Order-No. 202212

Specifications M 300

Condenser studio microphone with cardioid polar pattern

Polar pattern		Cardioid
Acoustical operating principle		Pressure gradient transducer
Frequency range		40 ... 18000 Hz
Sensitivity at 1 kHz		12 mV/Pa
Output impedance		100 Ω
Equivalent loudness level due to inherent noise	CCIR 468-4	26 dB
	DIN EN 60 651	16 dB - A
Signal-to-noise-ratio (re. 1 Pa at 1 kHz)	CCIR-weighted	68 dB
	A-weighted	78 dB
Max. SPL for THD ≤ 0,5 %		147 dB
Total dynamic range of microphone amplifier		131 dB
Current consumption (P 48, DIN 45596, IEC 268-15)		3,3 mA
Output connector		3-pin XLR connector goldplated contacts
Weight		126 g
Dimensions (L x Ø)		130 mm x 21 mm

CE Certificate

Frequency responses M 300

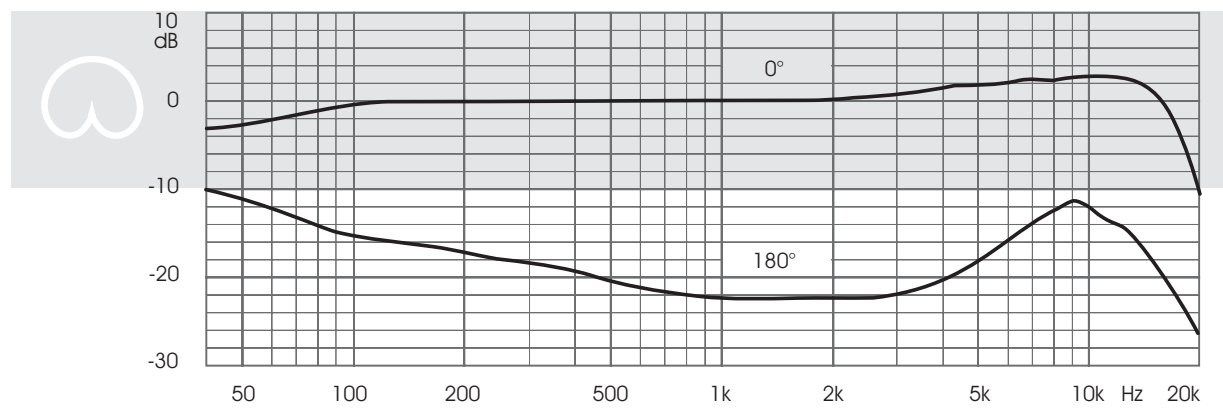

Polar patterns M 300

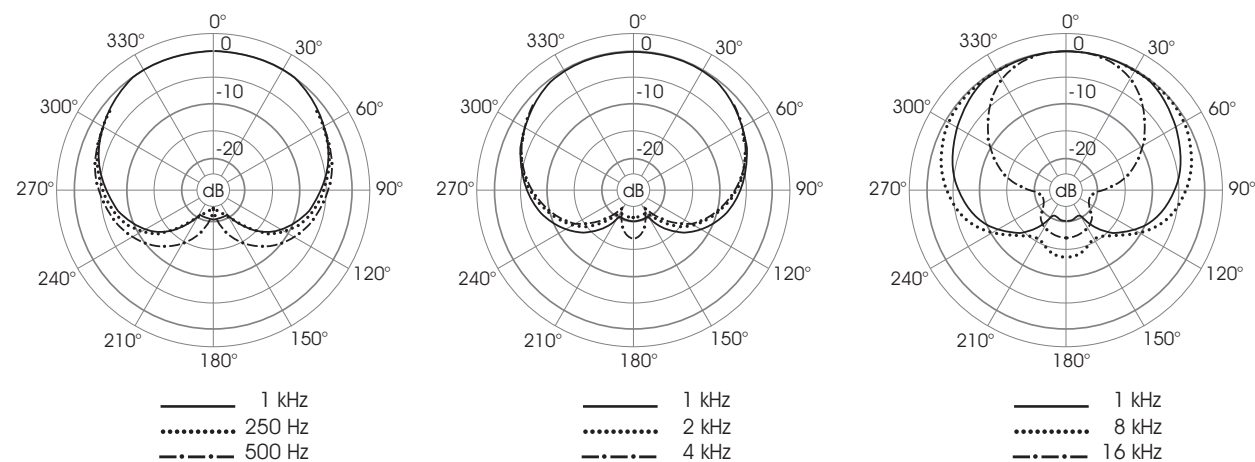

XY- and ORTF-stereo recording



Delivery

Mached pair of miniature condenser microphone M 300 for XY and ORTF-stereo recording with microphone holder MH 64.1, double mount TD 93, in a wooden case

L x B x H 195 x 68 x 43 mm

dark bronze

Order-No. 211174



picture 1: XY-arrangement



picture 2: ORTF-arrangement